



Datumstempel dater

Werknorm
company standard

Normgruppe
norm group

WN-T005

T=Teilekennzeichnung
part identification

Bsp.: Ø
D2186

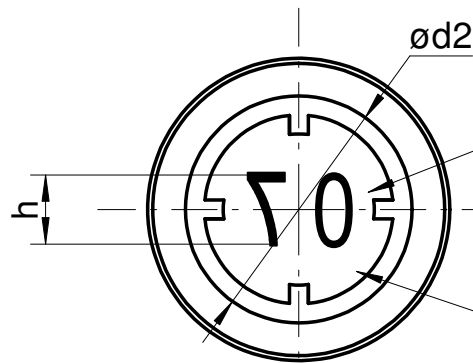

"XX"=Jahr
"XX"=year

Felder f. Kennzeichnung
Gießmonat m. Körnerspitze

fields f. marking cast month
with prick punch

M 5:1

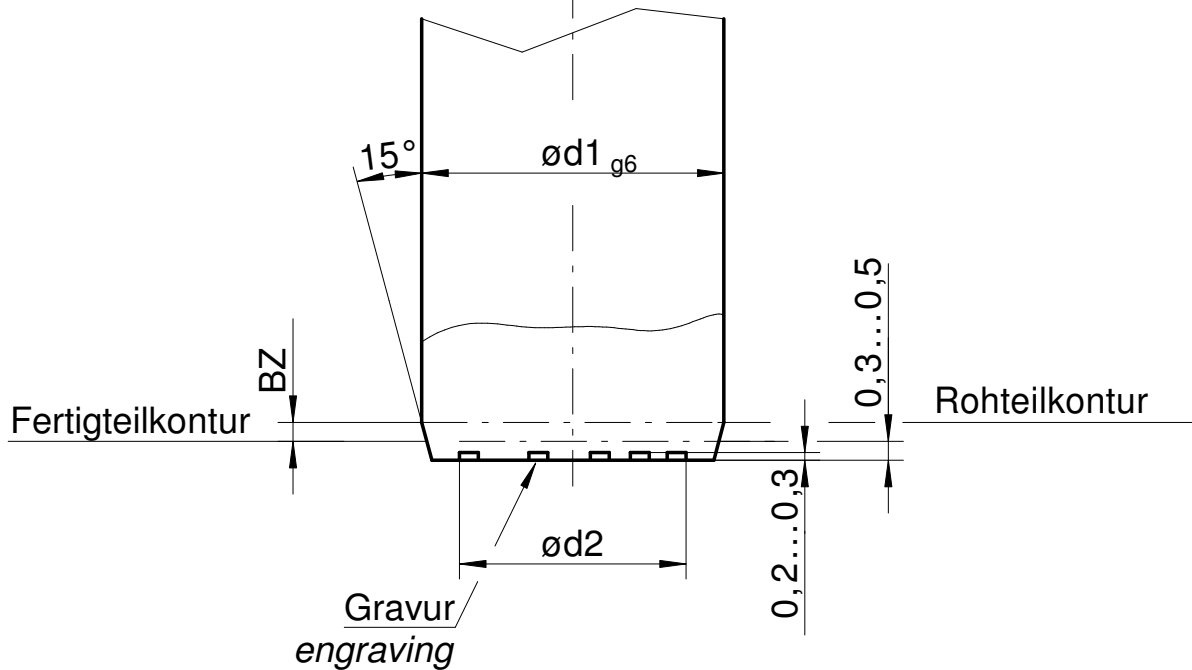

Werkstoff: 1.2343
geh. 46-2 HRC

material: X37CrMoV5-1
heated: 46-2 HRC

	"XX"	d1	d2	h
Ausführung version	/8-XX	8	6	2
	/10-XX	10	8	2,5
	/12-XX	12	9	3
	/14-XX	14	10	3,5
	/16-XX	16	12	4
	/20-XX	20	15	5

3. Änderung:					
2. Änderung:					
1. Änderung:					
Erstausgabe	Datum 04.10.06	Bearbeitet: <i>Thielke</i>	Gesehen: <i>Schneider</i>	Geprüft:	Name Änderung